



# ENOITALIA

## ENOLOGICAL EQUIPMENTS

***USER INSTRUCTIONS, INSTALLATION AND TECHNICAL MANUAL***

# **MOTORISED DESTONER DELTA**

**ENOITALIA s.r.l.**  
50050 CERRETO GUIDI (FI)  
Tel.+39 0571 588031  
fax +39 0571/588080  
[www.enoitalia.net](http://www.enoitalia.net)  
[info@enoitalia.net](mailto:info@enoitalia.net)



**WARNING:**  
*This manual should be kept near the machine in a place known to personnel responsible for operating, servicing and repairing the machine*

## ***1. INDEX***

|   |              |
|---|--------------|
| <b>1. INDEX.....</b>                                    | <b>.....</b> |
| <b>2. CONTENTS OF THE MANUAL.....</b>                   | <b>.....</b> |
| <b>3. SAFETY REGULATIONS</b>                            |              |
| <b>4. DESCRIPTION OF THE MACHINE .....</b>              | <b>.....</b> |
| <b>5. SAFETY GUARDS AND ACCIDENT PREVENTION .....</b>   | <b>.....</b> |
| <b>6. INSTALLATION.....</b>                             | <b>.....</b> |
| <b>7. WASHING AND CLEANING FIRST INSTALLATION .....</b> | <b>.....</b> |
| <b>8. ELECTRICAL WIRING .....</b>                       | <b>.....</b> |
| <b>9. STARTING UP AND STOPPING .....</b>                | <b>.....</b> |
| <b>10. WASHING AND MAINTENANCE.....</b>                 | <b>.....</b> |
| <b>11. TROUBLESHOOTING .....</b>                        | <b>.....</b> |
| <b>12. TECHNICAL FEATURES .....</b>                     | <b>.....</b> |
| <b>13. WARRANTY.....</b>                                | <b>.....</b> |
| <b>14. EC DECLARATION OF CONFORMITY .....</b>           | <b>.....</b> |

## 2. CONTENTS OF THE MANUAL

*This manual contains all the information and diagrams/ drawings needed for installing, running and servicing the stemmers.*

*It also sets out the safety regulations which personnel using the machine must observe.*

*This manual has been written for: Plant or Department Chiefs; Installation staff; Machine operators; Servicing staff.*



***Before using or repairing the machine, personnel must have read and understood the safety regulations contained in this manual. The manual is an integral part of the machine and must be made available for easy and rapid consultation. The manual should be stored in a suitable place far from potential sources of damage.***

***Specifically:***

- ***store it in a clean, dry place and notify all personnel for whom the manual is intended of its whereabouts***
- ***do not attempt to rewrite part of the manual.***

This manual is strictly pertinent to machines DELTA destoner in stainless steel.

## 3. SAFETY REGULATIONS

 **NON-OBSERVANCE OF THESE REGULATIONS MAY CAUSE ACCIDENTS TO PERSONNEL AND DAMAGE TO THE MACHINE**

Before commencing any operation on the machine read the instructions in the manual, supplementing the regulations specified herein with those required by current legislation on safety and accident prevention.

The moving parts of the machine can cause serious injury – operators should therefore pay the utmost attention when the machine is running. In addition, placing the machine in a damp area may be a source of accidental electric discharge caused by the electrical contacts of the motor.

Enoitalia s.r.l. therefore declines all responsibility in the case of:

- use of unsuitable electrical systems for operating the machine
- use of the machine in unsuitable environmental conditions
- failure to observe the installation, use and servicing instructions contained herein
- use of the machine by unauthorised, unqualified staff
- unauthorised modifications to the machine

**The machine has been designed specifically for the purpose indicated in the manual. Enoitalia s.r.l. declines all responsibility for any use of the machine other than that for which it has been designed.**

## 4. THE MACHINE

### 4.1. WARNING:



- The Destoner supplied must be used exclusively for processing the product described in this manual.
- Do not commence assembly of the Destoner or start it up before reading this manual.
- Do not turn on the Destoner if one or more of the warning signs are damaged or missing.
- Do not turn on the Destoner if the machine is vibrating abnormally or if the protective guards supplied have not been attached.
- Do not perform servicing, dismantling or cleaning operations before the machine has come to a complete standstill and the electricity supply has been turned off for several minutes.
- Do not turn on the machine if the electric motors or frame are cracked. Check the tightness of the various components at least once a year and if necessary tighten any loosened nuts or bolts.
- Check that the voltage of the circuit which the motor control panel is connected to corresponds with that of the motor cables.
- Do not try to operate an overheated motor but leave it to cool down to room temperature.
- Allow only experienced personnel to start up, clean or service the machine.
- Do not start up the motors if the rotating elements do not turn freely.
- Use harnesses to raise the machine and make sure that these are suitable for the weight to be lifted.
- Wash the machine with non-toxic products designed for use with food stuffs.
- This manual must stay with the machine at all times, any reproduction of the same, even partial, is strictly forbidden.

### 4.2. DESCRIPTION

The Destoner is a machine used for destoning ripe fruit like apricot, plums, peach, cherry, etc, suitable for use by small-medium sized farms

1) code 801, 802, 803 DELTA /ZERO 1/2/ single-phase or threephase



The machine is composed of the following parts:

- 1) **loading hopper**, inside which there is a motorized screw and a protection grid.
- 2) **Destoning basket**, separates the fruit pulp from the stone, by rotation of the central shaft. The separated grapes are collected in the tank below the machine fitted with fitting DIN 80 (for delta 1/2), or a pipe DN 60 (for delta zero)
- 3) **Stone outlet**: the stalks are eliminated by falling into the bottom of the machine. Only the stone falling to the ground should be eliminated and not those on the outlet blades of the machine. To remove these, stop the machine, disconnect the plug from the electric socket and extract the stalks.



**NEVER PERFORM THIS OPERATION WITH THE MACHINE ON**

- 4) **Electric motor** with emergency stop button, cable and plug. The user's electrical system must comply with current legislation and bear in mind the maximum power draw foreseen for the machine.
- 5) **Safety grid** provided with the machine must be fitted on the top of the hopper to prevent access of the arms to the area where the shaft is in motion

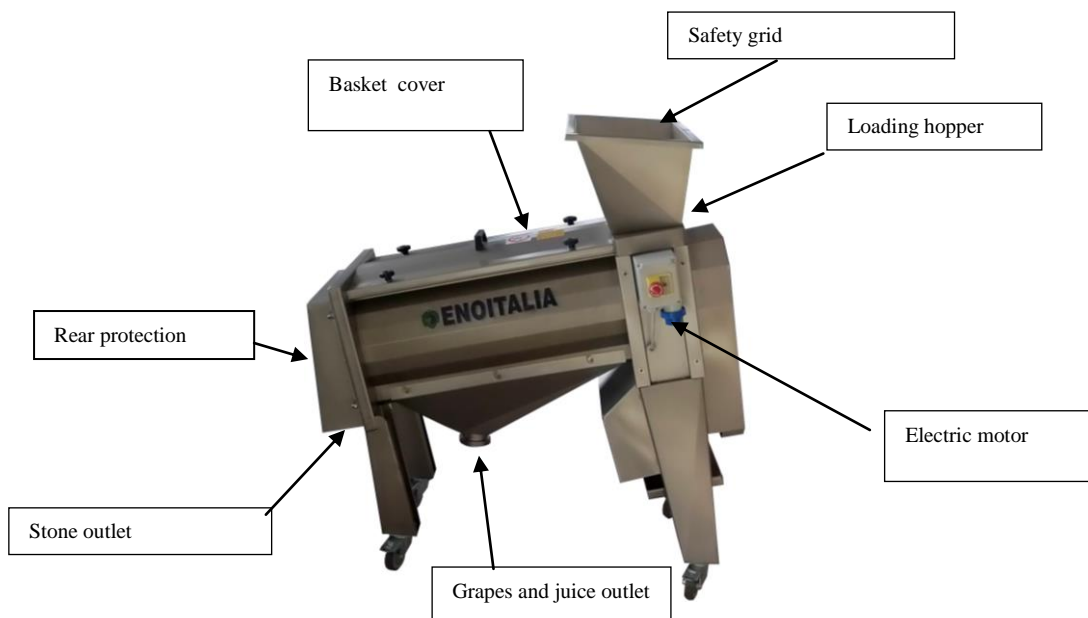

Figure no.1 Description DELTA 1

**The Destoner** has been designed exclusively to perform the following operations:

- to separate the stone from the ripe fruit by means of the grid and the destoner shaft
- pressing of the fruit

*We recommend that the user assess the suitability of the premises where the machine will be positioned by posing the following questions: is the machine easy to access from all sides and can the emergency button positioned on the conveyor duct be reached? Is there at least one metre of room around the machine, Is the machine obstructing the passage of forklift trucks or other means of transport? Is the floor which the machine is placed on able to withstand its weight when full? Does it have an inclination of more than 10%?; Is exposure to the noise of the machine distributed among the operators so as to fall within the limits foreseen by current legislation? Are the temperature, humidity and magnetic fields going to damage the machine? Will they allow it to function correctly Is the lighting sufficient for optimal performance of activities?*



Any changes to the conditions of use of the machine, either in terms of the products processed or of the operations performed, relieve the manufacturer of any responsibility in that a new commissioning must be performed pursuant to Directive 98/37/EC.

## 5 SAFETY GUARDS AND ACCIDENT PREVENTION

### 5.1. GENERAL REMARKS

The machine is designed so that the moving parts of the transmission gears and motor are protected by casings for the purpose, preventing direct contact. The machine is also provided with a safety grid (figure 1) which must be attached to prevent unintentional contact of the rotating part (shaft) with limbs or tools, but to allow transit of the product.



**Do not put your arms or any tools inside the machine when it is on.**

The employer, or head of the company using the machine, must make sure that all personnel responsible for using the stemmer have been informed of the safety regulations relative to use of the machine and must provide all the information necessary for safe use of the same.

Specifically they must check that:

- the machine has not been tampered with or modified
- the machine is used for the purpose specified in this manual
- the machine complies with its original configuration
- the safety regulations foreseen by current legislation and those indicated specifically herein are observed

From an analysis of the risks (conducted in conformity with the Machinery Directive 98/37 EC) connected with use of the stemmer it emerged that the main risks are as follows:



**Figure n.2 DANGER SYMBOLS AND PRECAUTIONS**

**Do not remove safety devices-Do not repair or adjust while in movement-Protective gloves obligatory-Protective footwear obligatory**

|   |  |   |
|---|--|---|
| Crushing and/or shearing of upper limbs                         | Destining shaft<br>Transmission organs | Do not remove the safety guards<br>Stop the machine or disconnect the plug from the mains when cleaning or servicing.<br>Do not repair when the machine is on.  |
| Crushing of lower limbs   | Falling of the machine                 | Use protective footwear<br>Make sure the machine is stable especially as regards positioning of the containers containing the grapes.   |
| Electrocution following contact with live parts.<br>Fire Hazard | Electric motor                         | Check that the mains voltage is compatible with the specifications on the motor data plate<br>Check the condition of the electrical cables<br>Protect the motor from damp<br>Only allow qualified personnel to perform repairs of the electrical system |

**Table 1:** General risk summary table

## 5.2. ELECTRIC EMERGENCY STOP BUTTON

The machine is provided with an emergency stop button which immediately cuts off the electricity supply to the motor, and a termic protection to avoid overloading of the engine

One emergency stop device is used:

1) RED stop button

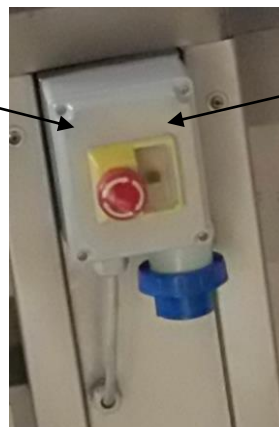

2) BLACK start button

singlephase engine for DELTA ZERO:



### 5.3 STICKERS ON THE MACHINE



Adhere strictly to the decals on the machine, especially those that relate to security

The stickers on the machine are an integral part of the machine itself, and possibly damaged and unreadable must be requested at the dealer or to Enoitalia srl, and replace



Fig n°10 stop of the machine, and disconnect from the main



Fig 11 read carefully the manual before start the machine



Fig 13 prohibition maintenance with machine on  
Prohibition harm inside with machine on

## 6. INSTALLATION

### 6.1. PRELIMINARY INSPECTION

The destoner is supplied in a package containing: no.1 instruction manual; no. 1 fully assembled destoner with power supply cable and plug . The safety grid is install inside the hopper.

After unpacking the machine check that it is in good condition, if necessary informing the manufacturer of any evident defects. Notify Enoitalia s.r.l in writing of any defects found within a fortnight of receiving the machine.

Check that the machine corresponds to the order specifications.



**When moving the machine, observe safety regulations on the movement of goods. If using automatic hoisting devices, check that the weights are correctly balanced. If the machine is to be moved manually make sure that the brakes are disabled**

Dispose of the packaging as required by current legislation.

### 6.2. POSITIONING

When positioning the destoner consider the aspects mentioned above in relation to the choice of site.

The height at which the destoner should be placed should be such as to prevent the operator from accessing the rotating shaft with his/her hands or arms.



**To such purpose remember that it is OBLIGATORY to fit the safety grid inside the loading hopper. That grid is an integral part of the machine, and standard accessory to ensure safety of the same.**

## 7. WASHING AND CLEANING THE MACHINE FIRST INSTALLATION.

Wash the machine thoroughly to eliminate any manufacturing residues and the dust which has built up on the surface, taking care not to wet the electrical parts and keeping the power supply cable disconnected.

Following is described the opening system

Remove the four locking bolt to remover the rear protection (it could be necessary to lose the grub screw of the central bearing), and remove the 4 knobs to remover the basket cover.

Remove the shaft. Lose the bolt of the basket and remove the basket.

The machine is completely open and accessible for cleaning. It is possible remove also the lower collection tank to have a better washing.

After cleaning, reinsert the basket and block with bolt. Then install the shaft, and the rear protection

Once the machine has been washed, install the safety box (as shown in figures 1 and 4).

If the electrical parts do get wet, dry them fully before starting up the machine.

## 8. ELECTRICAL WIRING

Before connecting the plug of the motor to the mains, check that the voltage of the motor corresponds with that of the mains.



**The electrical safety of the machine is only ensured if it is connected to an efficient earthing system, wired according to current electrical legislation.**

Inspection and any installation of appropriate electrical components must be performed by qualified personnel.

The use of multiple sockets or adaptors is not recommended; should use of the same be indispensable use only products corresponding to current safety legislation, observing the capacity limit in terms of current and maximum power. Use a cable of 1.5mm section for extension leads of up to 20 m, and 2.5 mm for longer leads.

## 9. STARTING UP AND STOPPING



**Before starting up the user should make sure that there are no impediments obstructing movement of the mechanical parts and, above all, make sure that nobody is in the vicinity of the parts about to move; specifically that nobody has their hands, arms or other parts of the body near the stalk outlet or inside the box.**

Check, in addition, that the voltage of the motor corresponds with the mains.

Check that all the safety guards are correctly installed on the machine.

Check that the emergency stop button works properly.

**After installing the safety box, in the case of three-phase 380V powered machines, start the machine and check through the hopper, if the direction of rotation of the shaft is clockwise. Otherwise, stop the machine, unplug it from the main, and invert two phases of the electrical connection from the cable side of the connection to the main**

Install a collection tank for the stones below the rear protection, in order to avoid these are thrown away from the machine.

Then install a collection tank for the fruit pulp under the outlet fitting, or connect a pump suction from the fitting (model DELTA 1-2 only).

If this preliminary inspection should reveal problems or prove negative, stop the machine, disconnect the plug from the mains, notify the department chief, the supplier company, if applicable or Enoitalia s.r.l.

Should this preliminary inspection be successful, proceed as follows:

- *press the button on the control panel of the electric motor and the machine will start.*
- load the ripe fruit .
- the machine will begin to destone the fruit. The stone will fall into the collection recipient, and the pulp will exit from the connection fitting .
- to stop the machine, press the red emergency button.
- to start the machine, release the emergency button and start up the machine again

Should work need to be done on the inside of the machine body (obstructions or foreign bodies) proceed as follows:

1. turn off the machine and disconnect the power supply cable
2. use a tool to remove the foreign body and, if necessary, open the machine
3. close any parts opened and repeat the steps described for start-up.

 **Do not put your hands, feet or tools in the machine when it is moving**

## 10. WASHING AND SERVICING

After using the machine and in any case at the end of the day's work, **remember to disconnect the electricity supply by turning off the mains switch and removing the plug from the socket.** This operation is essential to prevent accidental start-up of the machine which could cause damage to the machine itself or injury to persons.

After disconnecting the machine from the electricity supply, wash it to remove any processing residues, taking care not to wet the electrical parts.

*To wash the machine thoroughly, open it and remove the internal basket.*

*For washing, use warm water pressure and neutral detergent suitable for contact with food*

After washing, if the machine is to remain inactive for a long period, lubricate as follows:

- grease the chains and moving parts
- lubricate the gears , bearing supports and Teflon supports
- lubricate the conveyor screw, stemmer shaft and the screw in the lower tank.

*Correct performance of the servicing as above makes the components subject to wear last longer. To improve maintenance operations we recommend recording the date and type of operation performed.*



**All servicing must be performed by qualified, authorised personnel or directly by Enoitalia s.r.l. use lubricants suitable for coming contact with foodstuffs.**

The electric motor may in no case be dismantled. In case of need contact the supplier or Enoitalia s.r.l.

Should repair operations be necessary use original spare parts ordered from the retailer or directly from the manufacturer.



**The use of non-original spare parts without authorisation from Enoitalia s.r.l, will lead to lapsing of the warranty and of the Declaration of Conformity of the machine.**

## 11. TROUBLESHOOTING

| <i>PROBLEM</i>                      | <i>REMEDY</i>  |
|-------------------------------------|--|
| The machine has difficulty starting | Check that the power supply voltage is correct<br>Do not use extension leads of insufficient diameter which may cause drops in voltage.<br>Check the tightness of the transmission belt using the regulator.   |
| The machine will not start          | Check that the machine is plugged in.<br>Check that the circuit breaker switch is on and correct setting .<br>Check the emergency stop work correct  |
| Stone are with pulp                 | Check the tightness of the transmission belt<br>Check the shaft and adjust the distance between the inox plate and the basket<br>Reduce the quantity of the loading fruit<br>Make sure the fruit you are working is ripe or pass before 1 hour in hot water<br>Make sure you are using a basket with correct hole for the worked fruit |

|   |   |
|---|---|
| Noisy destoner basket, or the machine jerks | Check the distance between the destoning shaft and the basket<br>Check the gear transmission alignment inside the machine<br>Check gear transmission wear |
|---|---|

**Available screen:**

**8mm for apricot**

**6mm for plums**

**3mm for cherry**

**2 / 1,5 / 1 / 0,8 mm for mash**

## 12. TECHNICAL FEATURES

The data plate on the machine shows the identification details of the manufacturer and of the machine.

|  | DELTA ZERO    | DELTA 1                                |
|--|---------------|--|
| Measurements LxDxH mm                      | 1200X700X1420 | 1400x700x1420                          |
| Weight                                     | 80 kg         | 150 kg                                 |
| Hourly production kg/h                     | 550           | 1200                                   |
| Electric motor singlephase /<br>threephase | 2 hp (1,5 Kw) | 4 hp (3 Kw)/ 5,5hp (4kw)<br>THREEPHASE |
| Motor speed                                | 1400 rpm      | 1400 rpm                               |
| Electric voltage and frequency             | 230V 50/60 Hz | 220V 60 Hz/ 380V 50hz                  |
| Functioning temperature                    | 4C°-60C°      | 4C°-60 C°                              |

**Noise:** Leq weighted A 78.9-83.8 db. (measured in an outdoor environment in normal working conditions , according to the method indicated in UNI EN ISO 11202) below the limits foreseen by 2006/42 EEC legislation (<85dB)

## 13. WARRANTY



The machine is covered by a warranty for 12 months from the date of commissioning. In the absence of immediate use the warranty applies for up to 18 months from the date of delivery and then lapses.

The warranty does not cover transport of the machine, which is the purchaser's responsibility, and lapses in the event of use not in compliance with the instructions of this manual.

Repairs are understood to be ex our Cerreto Guidi plant (FI); they do not include transport which is the purchaser's responsibility.

Defects dependent on the following are excluded from the warranty and will entail the cessation of any obligation:

- incorrect installation
- tampering with the machine
- inexperience, lack of servicing, untimely notification of defects
- failure to observe the provisions of this instruction manual.
- repairs by personnel not authorised by Enoitalia s.r.l.
- transport damage which cannot be traced to manufacturing or packaging defects
- installation and use in electrical systems other than those indicated in the manual and on the data plate on the motor
- transports costs and risks in the case of forwarding the machine to authorised servicing centres
- consumables and ordinary servicing costs present in this manual.

The warranty does not extend to cover compensation of damages to persons and or things deriving from use of our product, even if in the case of the breakage or defect.

Failure to honour the agreed terms of payment will entail immediate lapsing of the warranty.

Any complaints should be notified by the purchaser within 8 days of purchase, in writing, to ENOITALIA s.r.l.

Retention of ownership: as provided for by articles 1523-1524 and following of the civil code, the transfer of ownership of the goods on sale will be subsequent to complete payment of the agreed sum.

The competent court for any dispute arising in relation to this contract is the court of Florence. Even in the case of foreign citizens or goods supplied abroad, any dispute will be regulated by Italian law.

ESPLOSO ALBERO (11)

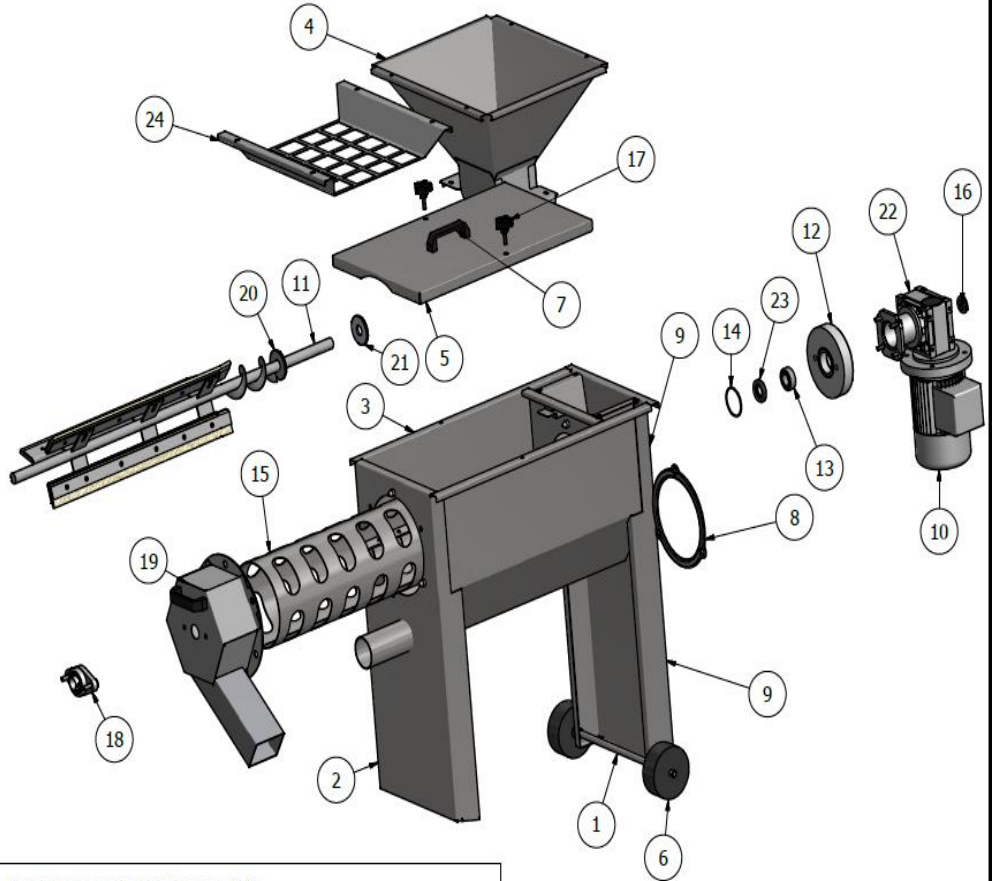
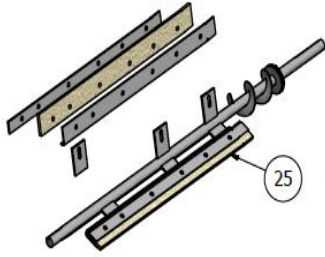

ELENCO PARTI

| ELEMENTO | QTÀ        | NUMERO PARTE                  |
|----------|------------|-------------------------------|
| 1        | 520,000 mm | Albero ruote                  |
| 2        | 1          | Fiancata-scarico              |
| 3        | 1          | Bandone                       |
| 4        | 1          | Tramoggia                     |
| 5        | 1          | Tappo                         |
| 6        | 2          | Ruota W031                    |
| 7        | 2          | Maniglia A22                  |
| 8        | 1          | Guarnizione G delta0          |
| 9        | 1          | Fiancata-motore               |
| 10       | 1          | Motore 1,1 Kw                 |
| 11       | 1          | Albero                        |
| 12       | 1          | Disco alluminio (Discodelta0) |
| 13       | 1          | Cuscinetto R05                |
| 14       | 1          | O-ring G3256                  |
| 15       | 1          | Rete                          |
| 16       | 1          | Rondella-albero-riduttore     |
| 17       | 2          | Pomelli A23                   |
| 18       | 1          | Cuscinetto R07P               |
| 19       | 1          | Scarico                       |
| 20       | 1          | Rondella inox                 |
| 21       | 1          | Rondella teflon               |
| 22       | 1          | Riduttore (Ridudelta0)        |
| 23       | 1          | Paraolio G03                  |
| 24       | 1          | Rete sicurezza                |
| 25       | 3          | Pale delta0                   |

SMONTAGGIO CUSCINETTO (18)

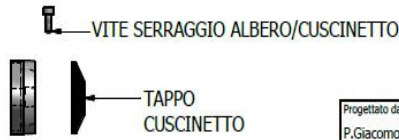

|                            |                |              |                     |                    |                             |
|----------------------------|----------------|--------------|---------------------|--------------------|-----------------------------|
| Progettato da<br>P.Giacomo | Controllato da | Approvato da | Date                | Date<br>11/06/2018 |                             |
| ENOITALIA                  |                |              | esploso delta0 2018 |                    | Edizione<br>Foglio<br>1 / 1 |

ENOITALIA  
 Via Procl. Pisana, 182  
 Tel. +39-0571-875021  
 53050 Pupilli - CERRETO GIULIO (SI)  
 Partita IVA 03997590488

# EC Declaration of Machinery Conformity

Manufacturer and seller of the machine

ENOITALIA s.r.l.  
Via Prov. Pisana, 162 Cerreto Guidi (Fi)

MODEL

**DELTA ZERO**

Destoner

Year of manufacture: 2020

The undersigned company hereby **DECLARES** at its own responsibility that the machine which this declaration refers to complies with the provisions of :

- Directive 2006/42/EC (machinery directive) and subsequent modifications and national dispositions of enactment.
- Directive 2006/95/EC (low voltage directive) and national dispositions of enactment.
- Directive 2004/108/EC (electromagnetic compatibility directive) and national dispositions of enactment.

The machine also complies with the Harmonised Standards

UNI EN : 349; 954/1; 1050; 547-1-2-3 ; 894-1-2-3 ; 953; 981; 1005-1-2-3-4-5; 1037.

UNI EN ISO: 3744; 7000; 12100-1-2; 11202; 11205 ; 11688-1-2; 14121-1; 13857;

UNI EN ISO 1186.

Technical standards and specifications CEI EN 60204/1.

National technical standards and specifications: UNI ISO 1819; UNI ISO 7149;

UNI 7544; 45020; 60447; 60447.

Cerreto Guidi 24/09/2020

The Manufacturing Chief

Falorni Fabio



..